

Opportunity No. OPP-463852
Issue Date 04/30/2014
Expiry Date 10/16/2014
Customer Contact Bill Hart
Payment Terms 30 DAYS

Sales Contact Jennifer Academia
Phone (760) 231-0676



Quote
AINC-0220818-Q

Altium Inc.
 2175 Salk Ave
 Suite 200
 CARLSBAD CA 92008
 USA
 Tel: +1 760-231-0760
 Fax: +1 760-231-0761
 E-Mail: sales.na@altium.com
 Web: www.altium.com

University of Arizona, Physics
 Physics Department University of Arizona
 1118 East 4th St.
 Tucson, AZ 85721
 UNITED STATES

Thank you for your inquiry. Taxes are estimated and delivery is within 14 days.
 All purchase orders should state that freight is 'prepay and add' and terms are 30 Days Net unless stated otherwise, on approved credit.
 If you have any further questions please do not hesitate to contact us.

Product	Quantity	Unit Price	Ext. Net Price
14-004-141-WCSD E Altium Subscription: On-Demand Commercial Renewal (Download only), AD2014 Single Site Subscription: 1-seat Commercial, Single Site, Altium Designer, On-Demand, Serial Number SN-06548733, Oct 16, 2014 - Oct 16, 2015	1.0	1,750.00	1,750.00
	Sub Total		1,750.00
	1) ARIZONA AZ STATE TAX (5.6)		98.00
	2) PIMA AZ COUNTY TAX (0.5)		8.75
	Total		USD 1,856.75

Nine Dot Connects LLC

Nine Dot Connects LLC
 PO BOX 6130
 MCKINNEY, TX 75071-6130

sales@ninedotconnects.com
<http://www.ninedotconnects.com>



Invoice

Date	Invoice No.
11/19/2013	1480
Terms	Due Date
Due on receipt	11/19/2013

Bill To
William Hart University of Arizona, Physics 1118 East 4th St. Tucson, AZ 85721 USA

PAID

Balance Due	Enclosed
\$0.00	

Please detach top portion and return with your payment.

Product/Service	Description/Activity	Quantity	Rate	Amount
AD:14-000-S	• Altium Designer - Time-based License - 12-month	2	480.00	960.00
Payment CC	• Credit card fee 2.5%	1	24.00	24.00

Bill hart two academic licenses \$480 each plus CC fee

Total	\$984.00
Payment	\$984.00
Balance Due	\$0.00



Z-Axis Connector Company
 345 Ivyland Road
 Warminster, PA 18974

Phone: 267-803-9000
 Fax: 267-803-9004
 Website: www.zaxisconnector.com

Invoice

Invoice Number: 13473
 Invoice Date: Feb 12, 2014
 Page: 1

Bill To:
University of Arizona Department of Physics 118 East 4th Street Tucson, AZ 85721

Ship to:
University of Arizona Department of Physics 118 East 4th Street Tucson, AZ 85721

Customer ID	Customer PO	Payment Terms	
University - Arizona	Verbal - Sarah	Credit Card	
Sales Rep ID	Shipping Method	Ship Date	Due Date
	UPS Ground	2/12/14	2/12/14

Quantity	Item	Description	Unit Price	Amount
50.00		Zwrap-305 Rev A Connector 102.70 x 6.50 x 2.40	22.000	1,100.00
1.00		Initial Setup Charge	475.000	475.00
1.00		Shipping and Handling	15.000	15.00

Subtotal	1,590.00
Sales Tax	
Total Invoice Amount	1,590.00
Payment/Credit Applied	
TOTAL	1,590.00

Check/Credit Memo No:



Invoice

Payer: 224453
 University of Arizona
 Radiology & Optical Sciences
 1609 N. Warren Avenue, Bldg. 211
 Tucson AZ 85724-1006

Invoice Number: 48303913
Invoice Date: 05-Dec-2013
Your Purchase Order: MC VRFOA2ACFDD0
Purchase Order Date: 05-Dec-2013
Terms of Payment: Due On or Before 30 Days
Terms of Delivery: FCA Factory (Incoterms 2010)

Bill To Customer: 224453
 University of Arizona
 Radiology & Optical Sciences
 1609 N. Warren Avenue, Bldg. 211
 Tucson AZ 85724-1006

Remit to Address:
 Mentor Graphics Corporation
 P.O. Box 841886
 Dallas, TX 75284-1886

Federal ID # 93-0786033
 Phone #: (503)685-7000 (800)592-2210

Electronic Payment Transfers:
 Bank of America
 Account Name: Mentor Graphics Corporation
 ABA Routing #: 121 000 358 ACH payments, Concord CA
 ABA Routing #: 026 009 593 Wire payments, New York NY
 Swift Code: BOFAUS3N
 Account #: 12334 27379

Ship To: 142196
 University of Arizona
 Physics
 1118 East 4th Street
 TUCSON AZ 85721-0001

Sold-to: 224453
 University of Arizona
 SITE: GIFTS/142196
 University of Arizona

Item	Part No.	Description	Quantity	Delivery Method	Taxable	Unit Price	Price
0010	255875	HEP Spt 2014-PCB PADS Bnd SW Perpetual	3 EA			0	0
		With the following configuration:					
		License Type			Extended Floating		
		Platform			Personal Computer Windows		
0020	255875	HEP Spt 2014-PCB PADS Bnd SW Support	3 EA		Y	166.67	500.00
		With the following configuration:					
		License Type			Extended Floating		
		Platform			Personal Computer Windows		
		Support Type			Support		
		Contract period: 01-Jan-2014 to 31-Dec-2014					
0030	219051	S/W SET, PADS Flow Perpetual	1 EA			0	0
0040	225243	S/W SET, Vendor Independent Flow Perpetual	1 EA			0	0
0050	240157	S/W SET,HyperLynx SI/PI/Thermal Perpetual	1 EA			0	0
0060	243020	S/W SET,PCB Matrix LP Wizard Perpetual	1 EA			0	0

Invoice

Bill To Customer: 224453
University of Arizona
Tucson AZ 85724-1006

Invoice Number: 48303913
Invoice Date: 05-Dec-2013

Item	Part No.	Description	Quantity	Delivery Method	Taxable	Unit Price	Price
0070	254719	S/W SET,Analog/Mixed Signal (AMS) Bundle Perpetual	1 EA	Electronic		0	0
						Items total	500.00
Taxable amount	500.00 at 8.10%.					Sales Tax	40.50
						Total amount USD	540.50

Customer will make all payments free and clear of, and without reduction for, any withholding or other taxes; any such taxes imposed on payments by Customer hereunder will be Customer's sole responsibility.

Unless otherwise agreed by the parties, any past due invoices will be subject to the imposition of interest charges in the amount of one and one-half percent per month or the applicable legal rate currently in effect, whichever is lower.

Your order for Mentor Graphics' products, support and/or services are subject to the terms of the applicable quotation and the agreement specified below. If you have a signed agreement with Mentor Graphics related to products or services in the order, your order is subject to the terms of that agreement. If you do not have a signed agreement related to the products or services in the order, the following terms apply unless otherwise specifically agreed to in writing by an authorized representative of Mentor Graphics:

- use of software (including any updates) is subject to Mentor Graphics' standard End-user License Agreement (EULA), which may be viewed at http://www.mentor.com/terms_conditions/enduser;
- support services are subject to Mentor Graphics' standard support terms, which may be viewed at <http://supportnet.mentor.com/about/legal/>;
- Other services (e.g. consulting, training) are subject to the terms specified in the applicable Mentor Graphics quotation for the order.

No modification, extension or waiver of terms shall be valid unless made in writing and signed by an authorized representative of Mentor Graphics. Any additional or different purchase order terms and conditions shall not apply.

These commodities, technology or software are subject to the United States Export Administration Regulations. Diversion contrary to U.S. law is prohibited.

IF YOU DO NOT AGREE TO THESE TERMS, DO NOT INSTALL OR USE THE PRODUCT AND RETURN IT TO MENTOR GRAPHICS IMMEDIATELY.

For questions regarding your account, please contact Linda Hing at +1-503-685-1192 or at MGCCollections_NA@mentor.com



PROTOQUOTE®

Prepared for:

University of Arizona

Quote Number: 312218 Quote Date: 5/9/2014

Part Name/Number: Silicon_support_FGS-straight_220_rev25

Extents: 220 mm x 10 mm x 6 mm

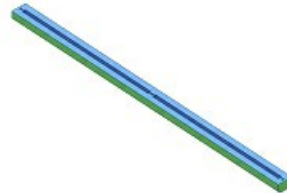

[View in 3D](#)

Thank you for the opportunity to quote your parts. We look forward to working with you on this project. Should you have any questions, please do not hesitate to contact us at 877.479.3680.

1 Confirm or Modify Specifications and Review Pricing

Cavities:	<input type="text" value="1 cavity"/>
A-side (green) finish:	<input type="text" value="PM-F0 (Non-cosmetic - finish to Protomold discretion)"/>
B-side (blue) finish:	<input type="text" value="PM-F0 (Non-cosmetic - finish to Protomold discretion)"/>
Tooling Price: \$2,775.00	
Sample Quantity:	<input type="text" value="25"/> Sample Parts 25 @ \$2.73: \$68.25
Material:	<input type="text" value="Nylon 66, Black 33% Glass Fiber (Zytel 70G33 HS1L BK0)"/>
	<input type="button" value="Change Material Color"/>
	<small>The selected material is not compatible with added colorants</small>
Lead Time:	<input type="text" value="Sample parts ship in 15 business days (standard lead time)"/>

⚠ You have chosen a glass-filled resin. Please note that parts molded with glass-filled resins are more likely to suffer from warp than are parts molded with unfilled resins.

Total USD: \$2,843.25

[currency calculator](#)

Production Parts Calculator

This calculator shows estimated piece part pricing for future production orders.

Qty 1,000:	\$2.73 ea	Custom Lot Size Pricing	
Qty 10,000:	\$1.75 ea	Enter Lot Size:	<input type="text" value="5000"/> <input type="button" value="Go"/>
Qty 100,000:	\$1.68 ea	Qty 5000:	\$1.79 ea

Add \$500.00 setup charge to each lot of production parts.

Production pricing in USD based on the material selected: Nylon 66, Black 33% Glass Fiber (Zytel 70G33 HS1L BK031)

2 Review Issues (2D View)

Required Changes (0)

Required Changes
The following illustrations indicate changes to the model which are required for compatibility with the Protomold process.

No required changes

Moldability Advisory

The following illustrations indicate part design considerations for optimal performance in the injection molding process.

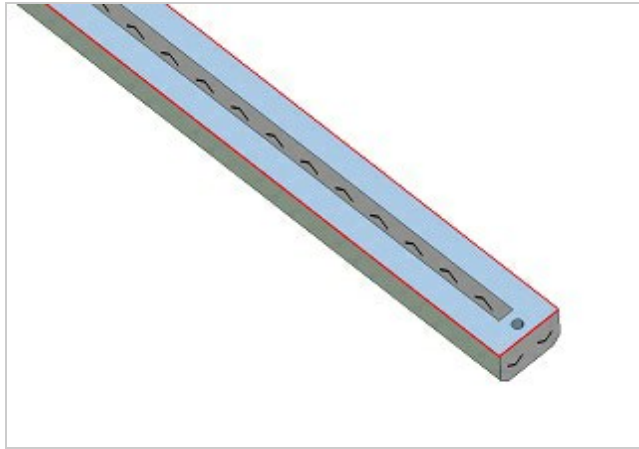

1. The faces with arrows currently have no draft. Draft is recommended on all injection molded parts. Protomold recommends adding 0.5 degree of draft if possible. Protomold will try to make your part as-is, without draft in this area, but there may be issues such as drag marks, distortion from ejection stresses, or other effects, any of which may cause delays. For details, clarification, options, or alternatives, please contact a Customer Service Engineer at customerservice@protolabs.com or 877.479.3680.

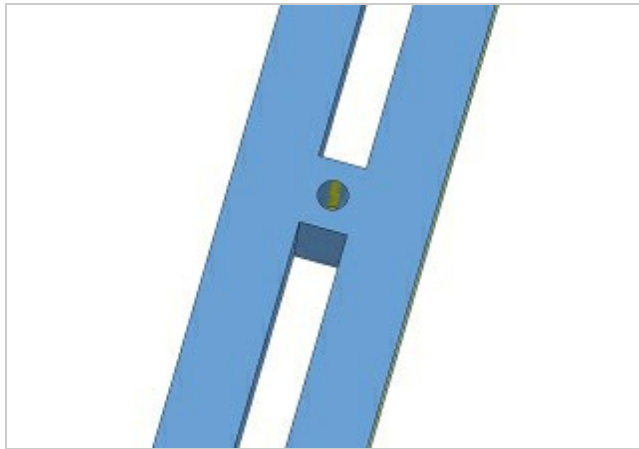

2. Yellow color coding indicates areas where part thickness is significantly less than nominal. These areas may have fill problems, weak weld-lines, through-holes or significant texture variations. See the [Recommended Wall Thickness by Resin](#) page and the [Uniform Wall Thickness](#) page for guidelines. For details, clarification, options, or alternatives, please contact a Customer Service Engineer at customerservice@protolabs.com or call 877.479.3680.

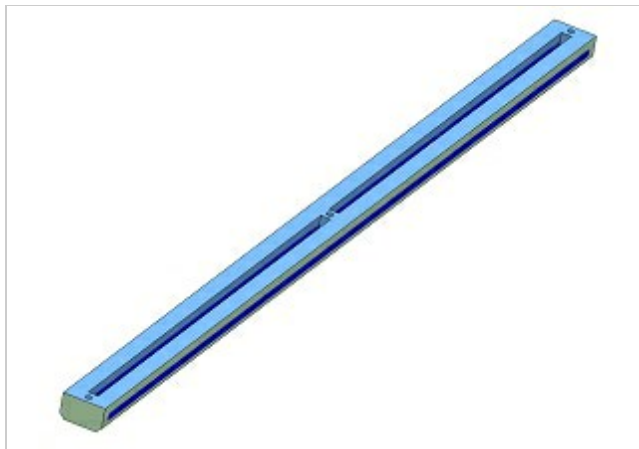

3. Dark blue color coding indicates areas where part thickness is significantly greater than nominal. Sink marks, voids, and excessive shrink are possible in these areas. Warp of these and other areas of the part may occur. See the [Recommended Wall Thicknesses by Resin Types](#) page and [Uniform Wall Thickness](#) page for design guidelines. For details, clarification, options, or alternatives, please contact a Customer Service Engineer at customerservice@protolabs.com or call 877-479-3680.

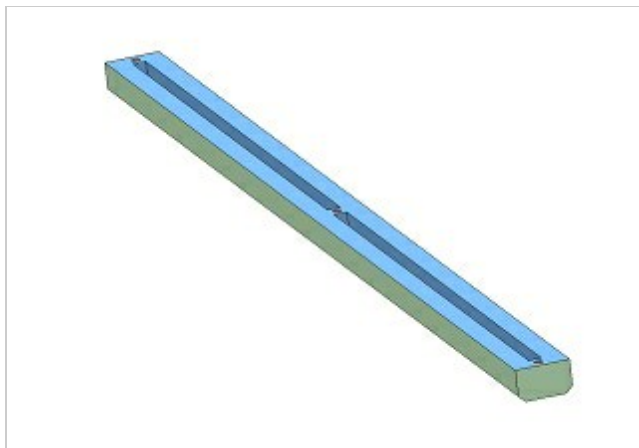

4. The mold for your part has long and thin or very small cores that are not practical in Protomold's aluminum tools. We will be creating hole features in your part with cylindrical steel pins sized at the largest diameter of the hole. The holes being created with steel pins are highlighted in orange within the image.

The following steel core pins will be used on this part:
 DiameterNumber of Pins
 1.5 mm 3

5. If you choose a textured finish on your part: PM-T1 (light

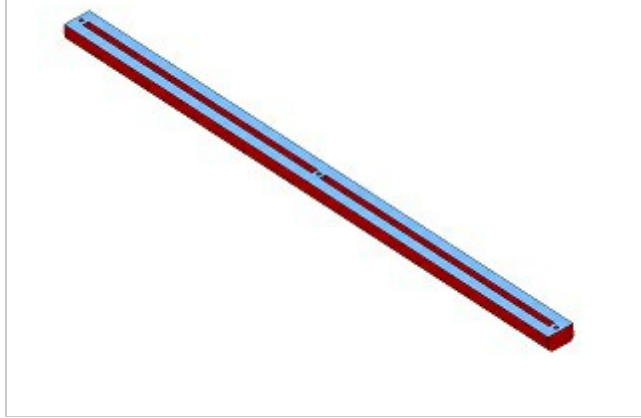

bead blast texture) generally requires at least 3 degrees of draft, and PM-T2 (medium bead blast texture) generally requires at least 5 degrees of draft. Faces colored red have a draft of less than 3 degrees, and faces colored yellow have a draft of 3-5 degrees. If you do want a textured finish on these faces, we recommend adding additional draft to avoid possible drag marks, cosmetic flaws, missing texture, and to assist in proper ejection of the part.

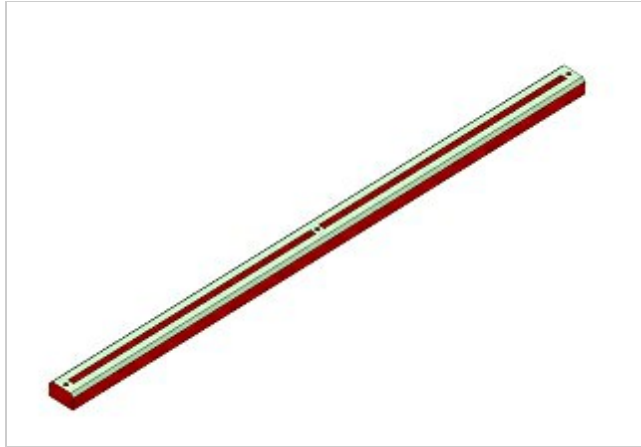

6. If you choose a textured finish on your part: PM-T1 (light bead blast texture) generally requires at least 3 degrees of draft, and PM-T2 (medium bead blast texture) generally requires at least 5 degrees of draft. Faces colored red have a draft of less than 3 degrees, and faces colored yellow have a draft of 3-5 degrees. If you do want a textured finish on these faces, we recommend adding additional draft to avoid possible drag marks, cosmetic flaws, missing texture, and to assist in proper ejection of the part.

Other Info (1)

Other Info

The following illustrations indicate general information about how your part will be molded and areas in which the molded part will differ from the geometry of the CAD model due to the milling process used in mold manufacture.

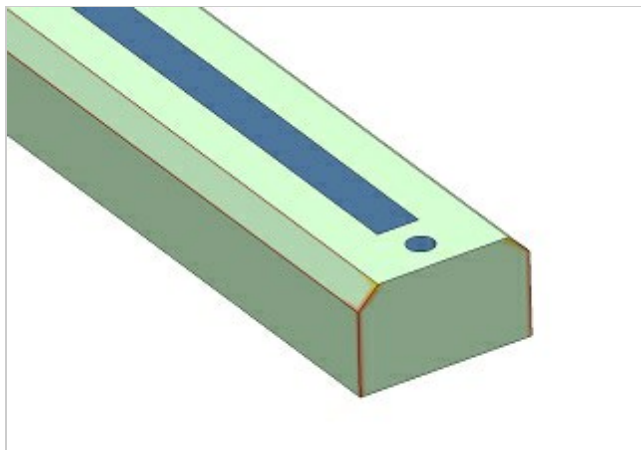

1. Corners that will have a radius due to the milling process are color coded as follows:

- radius = 0.28 mm
- radius = 0.40 mm
- unformed features

Note: This part has features that will not be fully formed (see dark red areas).

③ Summary

Order Pricing

Specifications Selected

Cavities	1	Tooling Price:	\$2,775.00
A-side (green) finish:	PM-F0	Sample Parts 25 @ \$2.73:	\$68.25
B-side (blue) finish:	PM-F0		
Sample Quantity:	25		
Material:	Nylon 66, Black 33%		
	Glass Fiber (Zytel		
	70G33 HS1L BK031)		

[Add to Cart](#)

[Upload a Revised Model](#)

Total USD: \$2,843.25

[currency calculator](#)

Notes

- Customers are responsible for ensuring that the properties and performance of the resin selected meet the requirements of their application.
- There is no provision within the Protomold process to make the tool "steel safe." Since dimensional tolerances are highly dependent on the material selected and on the part design, we are not able to guarantee that a specific tolerance will be met.
- A-side shown in green. B-side (ejection side) shown in blue.
- The expected tolerance in a well designed part in Nylon 66, Black 33% Glass Fiber (Zytel 70G33 HS1L BK031) is +/- (0.08 mm + 0.003 mm/mm).

Terms and Conditions — ProtoQuote Interactive Quote

Terms and Conditions of Sale – Proto Labs, Inc.

Seller. As used herein, "Seller" means Proto Labs, Inc. (including Firstcut, Protomold, and FineLine Services), a Minnesota corporation.

Quotations. A quotation is an offer to sell, is valid only for the 3D CAD model on which it was based, and is subject to these terms and conditions, all of which are deemed incorporated therein. Any change to the 3D CAD model requires an updated quotation. Quotations are valid for 30 days, after which pricing may change without notice. Seller reserves the right to correct clerical and other patent errors in any quotation.

Offer and Acceptance. This document from Seller, together with a valid quotation, contains the entire terms and conditions associated with this transaction. The buyer may accept a quotation by issuing a purchase order or other writing expressing its intention to be bound, or in any other manner acceptable to Seller. Any terms, conditions or writing within such a purchase order or writing addressing the subject matter of this transaction, shall be for the buyer's internal purposes only and the terms and conditions contained therein shall have no force or effect. Seller objects to any different or additional terms or conditions contained in any request for quotation, purchase order or other writing or document of the buyer, and no such different or additional terms shall be effective or binding upon Seller unless agreed to in writing and signed by an officer of Seller. After Seller accepts an order, buyer is responsible for any delivery delays or charges, in addition to the original price, due to a buyer requested change that is agreed to in writing by Seller.

Termination for Convenience. Buyer may terminate an order in whole or in part at any time by written or electronic notice to customerservice@protolabs.com, effective upon receipt by Seller. Upon receipt of such notice of termination, Seller shall promptly discontinue performance and comply with buyer's instructions concerning disposition of completed and partially completed items, work in progress, and materials acquired for the applicable order. In the event of termination, Seller shall be paid a minimum charge of \$100 up to the full purchase order price depending on work performed prior to receipt of notice of termination. Seller shall be paid the full purchase order price for all goods produced or services performed prior to receipt of notice of termination. This section shall not limit or affect the buyer's right to cancel this order for breach by Seller.

Delivery; Quantity; Title. Premium delivery options are subject to review at the time of order. Any stated delivery time represents Seller's intended or typical delivery time, but actual delivery times may vary. Seller reserves the right to limit quantities at any time. All parts are shipped FCA (Incoterms 2010) at Seller's facilities. Title passes to the buyer at the time and place of delivery to the carrier.

Price and Terms of Payment. All prices are quoted and payments shall be made in U.S. Dollars. Payment may be made by Visa, MasterCard, Discover, American Express, or a form of prepayment acceptable to Seller. Upon request, Seller will consider net 30 terms based on the buyer's history and credit references.

Taxes, Duties, Etc. The buyer shall pay all duties and sales, excise, use or other taxes arising in connection with this transaction (other than taxes based solely on Seller's taxable income).

Warranties. Seller assumes no responsibility for the design of the goods that are the subject of this transaction. To the extent that Seller's personnel recommend design modifications or provide design analysis, simulation or advice, they do so to help meet the requirements of Seller's own manufacturing process. The buyer retains sole legal responsibility for the design specifications and performance of the goods that are the subject of this transaction.

SELLER MAKES NO REPRESENTATION OR WARRANTY, WHETHER EXPRESS OR IMPLIED, OF ANY KIND WHATSOEVER WITH RESPECT TO ANY GOODS OR SERVICES, INCLUDING BUT NOT LIMITED TO ANY WARRANTY OF MERCHANTABILITY, FITNESS FOR A PARTICULAR PURPOSE OR NON-INFRINGEMENT.

Without limiting the generality of the foregoing, Seller assumes no responsibility or liability for the selection of any materials for the goods that are the subject of this transaction. The buyer is solely responsible for ensuring that materials selected for goods to be manufactured by Seller meet any regulatory requirements or specifications including but not limited to Directive -2011/65/EU on the restriction of the use of certain hazardous substances in electrical and electronic equipment (RoHS Directive) together with any national legislation implementing such Directive, ISO, FDA, UL, CSA, CE, TUV, FCC, NSF, and USP. Any statements made by Seller personnel or specifications provided by Seller regarding materials should be verified by the buyer with the manufacturer of that material.

Indemnification. The buyer shall defend, indemnify and hold harmless Seller (and its employees, representatives and agents) from and against all claims, liabilities, losses, damages, penalties, fines and sanctions of any kind (including, without limitation, interest, attorneys' fees and expenses,

customs duties, fines, taxes, penalties or any other governmental sanctions of any kind) (i) resulting from or arising out of any breach of any representation, warranty or covenant of the buyer or its affiliates hereunder; (ii) if the buyer has supplied Seller with drawings, designs or other specifications for the goods or services, arising out of any assertion that any goods manufactured by Seller (or the act of manufacturing such goods) according to those drawings, designs or other specifications infringe or misappropriate any patent, copyright, trade secret or other proprietary right; (iii) otherwise arising out of or related to this transaction. It is specifically understood that the buyer shall indemnify and defend Seller and hold Seller harmless from claims that Seller was itself negligent or otherwise at fault. If any action, suit or proceeding is commenced, or any claim, demand or assessment asserted against Seller (or its employees, representatives or agents) which may result in liability with respect to which a party seeks indemnification, then the party shall notify the buyer promptly and the buyer shall have the right at its own expense to assume the entire control of the defense, compromise or settlement. Upon the buyer's request and at the buyer's expense, Seller shall cooperate fully in such defense and make available to the buyer all relevant information under its control.

Force Majeure. Seller shall not be liable for any failure to manufacture, deliver or provide, or for any delay in the manufacture, delivery or provision of, any goods to be provided hereunder if such failure or delay is caused by acts of God, fire, storm, strikes, blackouts, labor difficulties, riots, inability to obtain materials, equipment, labor or transportation, governmental restrictions, serious public health nuisance or any similar cause over which Seller is unable to exercise control. In the event of any shortage of raw materials or other supplies, Seller may allocate materials and supplies among its buyers in such manner as Seller may determine in its sole discretion, and shall have no liability to the buyer on account of any delay or cancellation on account thereof.

Tooling. Due to the proprietary nature of Seller's process, all Tooling is proprietary and is generally not compatible with or transferable to other equipment. Notwithstanding any tooling or engineering charges imposed by Seller, all such Tooling shall be and remain the sole and exclusive property of Seller. However, Seller shall not use Custom Tooling in the production of goods for any other buyer of Seller without the buyer's express permission. As used in this Agreement, "Tooling" means all Seller proprietary software, processes, procedures, and tooling developed by Seller, for the quoting, analysis, design, automation, and manufacturing of machined parts, injection molds and injection molded parts, and "Custom Tooling" means tooling, molds, or fixturing developed specifically for the buyer and for which the buyer is separately charged by Seller.

Buyer-Supplied Materials. If Seller agrees to use materials supplied by the buyer, then the buyer shall be solely responsible for supplying and delivering such materials in a timely manner at no cost or expense to Seller, of sufficient quality and in sufficient quantity (including allowances for loss, waste, or scrap that may occur for any reason) as Seller deems necessary to complete its obligations. Seller shall not be liable for, and the buyer shall be obligated to pay any previously negotiated delivery premiums notwithstanding, any failure or delay in delivering any goods to be provided hereunder if such failure or delay is caused by the buyer's failure to supply and deliver such materials in a timely manner or of such quality or in such quantity as Seller deems necessary.

Text, Illustrations, and Software Files Provided by Seller. Copyright in files. All intellectual property rights to text, illustrations, software files and other materials ("Seller Materials") provided by Seller to buyer are retained by Seller. Buyer will not, without prior written approval of Seller (which may be withheld for any reason), remove any of Seller's markings or change in any way the Materials.

Text, Illustrations, and Software Files Provided by Buyer. Copyright in files. All text, illustrations, software files and other materials ("Buyer Materials") provided by buyer to Seller and, with the exception of Tooling or Custom Tooling as defined above, any deliverables, designs, or works of authorship in any form, including modifications or derivative works thereof, that may be created or produced for buyer during the course of Seller's performance of services shall be deemed the sole property of buyer and all right, title and interest therein shall be held solely by buyer.

Federal Government Contracts. If this transaction is a subcontract under a federal government contract or subcontract, the buyer and Seller agree that the goods and services provided by Seller to the buyer under this agreement constitute "commercial items" as defined in FAR 2.101 (48 CFR § 2.101). In this regard Seller warrants that the goods and services provided under this agreement are priced at the same rate and in the same manner as Seller's comparable commercial agreements for similar goods and services and that such goods and services are sold in the commercial marketplace, subject to modifications of a type customarily available in the commercial marketplace. The buyer and Seller further agree that the Seller will comply with only the contract clauses included in FAR 52.212-5(e) or FAR 52.244-6 (as applicable) and DFAR 252.212-7002(c) as of the date of this agreement, which clauses are incorporated herein by reference according to their FAR or DFAR prescription. Seller and the buyer agree that no other government contract clauses, including flow down clauses, are included in this agreement unless specifically agreed to in writing. Seller agrees to include the substance of this clause, including this paragraph, in any subcontracts awarded under this agreement.

Country of Origin. Seller makes no country of origin certification under this Agreement unless specifically agreed to in writing. Seller specifically disclaims any "passive" certifications included in any of buyer's documents or communications related to this Agreement.

Confidentiality. "Confidential Information" means any information that buyer discloses to the Seller (including without limitation to any of its directors, officers, employees, representatives, professional advisers or other agents (collectively, "Representatives")), whether in writing, orally, by inspection of objects or otherwise. Confidential Information does not, however, include any: (a) information that was publicly known and made generally available in the public domain prior to the time of disclosure to the Seller by buyer, or becomes publicly known and made generally available after disclosure to the Seller by buyer through no action or inaction of the Seller or its Representatives; (b) information in the possession of the Seller, without confidentiality obligations to buyer, at the time of disclosure by buyer as shown by the Seller's files and records immediately prior to the time of disclosure; (c) information that is later disclosed to the Seller by a third party under no obligation of confidentiality to buyer and without violation of this Agreement by the Seller or its Representatives; (d) information that is independently developed by the Seller; or (e) information that is required to be disclosed by law or governmental rule or regulation, or in connection with any judicial proceeding.

The Seller will not use any Confidential Information for any purpose except for the purposes of quoting and manufacturing of additive parts, manufacturing machined parts, injection molds and/or injection molded parts. The Seller will not disclose any Confidential Information to any individual, entity or organization, except to any of the Seller's Representatives as required for the purposes described herein. The Seller will use the same degree of care (but no less than a reasonable degree of care) to protect the secrecy of and avoid disclosure and unauthorized use of the Confidential Information as the Seller employs with respect to its own confidential and proprietary information. Upon buyer's written request, the Seller will destroy all documents containing or representing Confidential Information and all copies thereof, and erase any such Confidential

Information from the Seller's computer systems except electronic copies that are electronically archived and not readily accessible. If requested by buyer, Seller will provide written confirmation of such return or destruction and erasure to Buyer.

License to Use Software. As part of our Interactive Quote process, you may be asked to download ProtoView, a software application. Software that is made available to download from the Proto Labs systems ("Software") is the copyrighted work of Proto Labs, Inc. Any reproduction or redistribution of the Software is expressly prohibited by law. By downloading the Software, you agree to comply fully with all laws and regulations of the United States and other countries (Export Laws) to assure that neither the Software, nor any direct products thereof are (1) exported, directly or indirectly, in violation of Export Laws, or (2) are used for any purpose prohibited by Export Laws.

Classified Information. The buyer represents and warrants to Seller that no information furnished or to be furnished by the buyer to Seller, and no information required to manufacture or sell the goods that are the subject of this transaction, constitutes information classified by the U.S. federal government as confidential, secret or top secret or similar designation by any international government.

Export Compliance. Buyer and Seller will comply with all applicable export, restrictions and regulations of any U.S. agency or authority including but not limited to the Export Administration Regulations ("EAR") administered by the U.S. Department of Commerce, International Traffic in Arms Regulations ("ITAR") under the U.S. Department of State, and embargo controls administered by the U.S. Department of the Treasury's Office of Foreign Asset Controls ("OFAC") with respect to the goods or services that are subject to this Agreement. The parties will not export or re-export or allow the export or re-export of any goods, technology or information it obtains or learns pursuant to this Agreement in violation of any such law, restriction or regulation. Buyer shall be responsible for obtaining any export licenses or required authorizations to export or re-export any export controlled item or technology related thereto that it engages Seller to produce. Seller shall cooperate with Buyer's efforts to obtain such licenses or authorizations, provided, however, that Seller will not produce export controlled goods for export where the Seller would be required to apply for an Export License of any kind. In order for Seller to conduct appropriate export control checks, the buyer agrees to identify any export controlled (e.g., ITAR) goods in writing to Seller by the time buyer accepts a quotation and to provide all pertinent information pertaining to the particular end buyer, destination and intended use of goods. Seller reserves the right to stop shipping or providing goods if Seller has reason to believe that any shipment or sale of goods may violate any export control law.

Prohibited Purposes. Buyer warrants that the goods that are the subject of this transaction: (i) will not be implanted in a human body, and (ii) are not subject to FAA inspection.

LIMITATION OF DAMAGES. IN NO EVENT SHALL SELLER BE LIABLE FOR ANY INCIDENTAL, INDIRECT, CONSEQUENTIAL OR PUNITIVE DAMAGES OF ANY KIND, WHETHER FOR BREACH OF ANY WARRANTY, FOR BREACH OR REPUDIATION OF ANY OTHER TERM OR CONDITION, FOR NEGLIGENCE, ON THE BASIS OF STRICT LIABILITY, OR OTHERWISE. THE GOODS AND SERVICES ARE PROVIDED ONLY FOR BUYER AND/OR BUYER'S CUSTOMER IN CONTRACT PRIVITY WITH BUYER AND ARE NOT FOR THE BENEFIT OF ANY THIRD PARTIES.

Compliance with Laws and Regulations. Buyer certifies that its designs (e.g., 3D CAD models) submitted to Seller and the manufacture and delivery of goods according to the design will not yield goods that are in violation of any state, federal, or local law. Buyer will not hold Seller liable for any violation of state, federal, or local law that occurs as a result of manufacturing or delivering any goods according to the design provided by Buyer. Buyer agrees to indemnify, defend, and hold Seller harmless from and against all liabilities, damages, losses, expenses, claims, demands, suits, fines, or judgments, including attorneys' fees, costs, and expenses, which may be suffered by reason of any claim arising out of or relating to this transaction.

Miscellaneous. The rights and obligations of Seller and the buyer under this contract shall be governed by the laws of the State of Minnesota (without regard to principles of conflict of law), including the Minnesota Uniform Commercial Code. The United Nations Convention on Contracts for the International Sale of Goods shall not apply to this transaction. Any suit, action or other legal proceeding arising out of or relating to this transaction shall be brought in a court of record in Hennepin County, Minnesota or in the courts of the United States located in such county. Seller and the buyer each consent to the jurisdiction of each such court in any suit, action or proceeding, and waive any objection which it may have to the laying of venue of any such suit, action or proceeding in any such courts and any claim that any such suit, action or proceeding has been brought in an inconvenient forum. No quotation or contract, or series of quotations or contracts, shall establish any course of dealing or otherwise entitle the buyer to the same or similar terms in any future agreement with Seller. No blanket or similar uncommitted purchase order shall bind Seller, but any instructions issued by the buyer under any such purchase order (whether written, electronic, telephonic or otherwise) will bind the buyer as fully as if provided in a writing signed by the buyer.

English Language. All documents, notices and legal proceedings executed, given or instituted pursuant to or relating directly hereto shall be in the English language, and the meaning of all words and phrases of this offer shall be defined, construed and interpreted in the English language.

Proto Labs Rev April 25, 2014

[Refresh data.](#)

CNC Machining

protomold[®]
Injection Molding

protoworks[®]
Research & Development

Read Proto Labs Journal
Apply for a Cool Idea! Award
Upcoming Trade Shows
Customer Feedback
Get a Quote
Take a Tour

 LinkedIn

 Proto Labs Blog

 Twitter

 YouTube



Proto Labs, Inc., 5540 Pioneer Creek Dr., Maple Plain, MN 55359 USA | 877.479.3680
© Proto Labs 1999–2014
[Conditions of Use](#) | [Privacy Policy](#)

proto labs[®]
Real Parts. Really Fast.™