

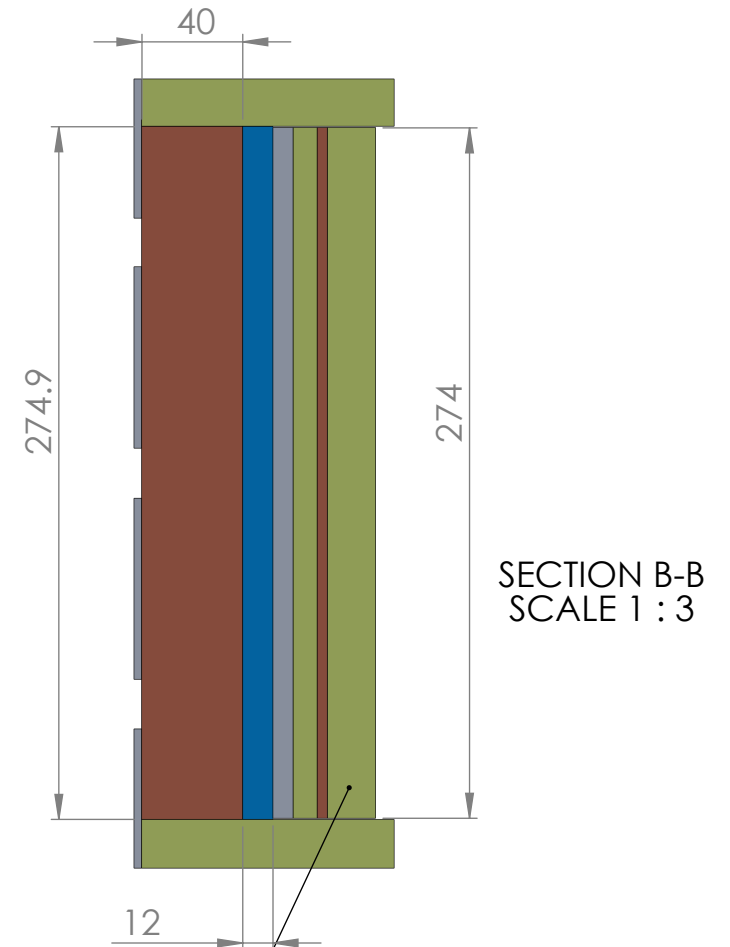

03/18/2015

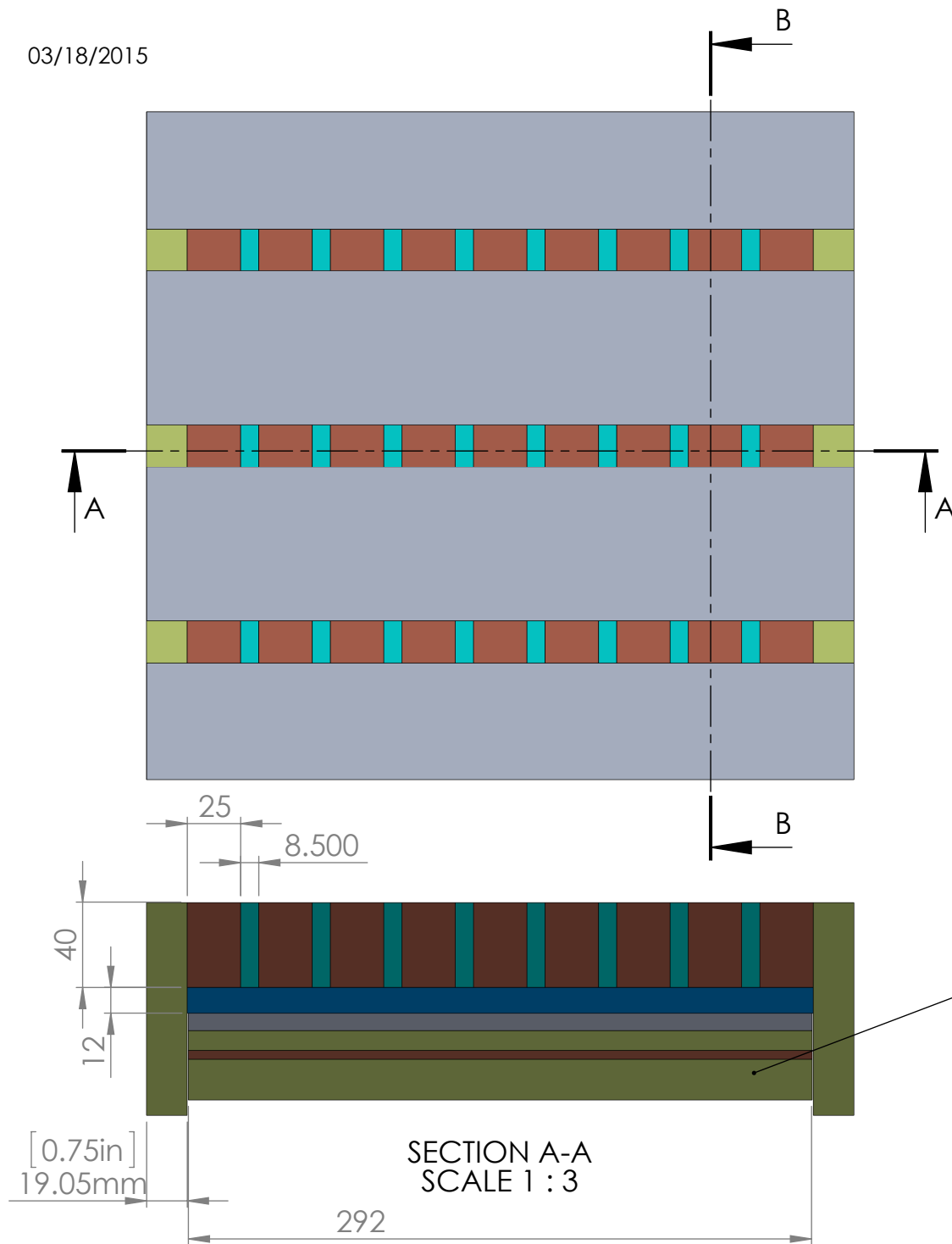

Heater Assembly  
Detail on Sheet 4

03/18/2015

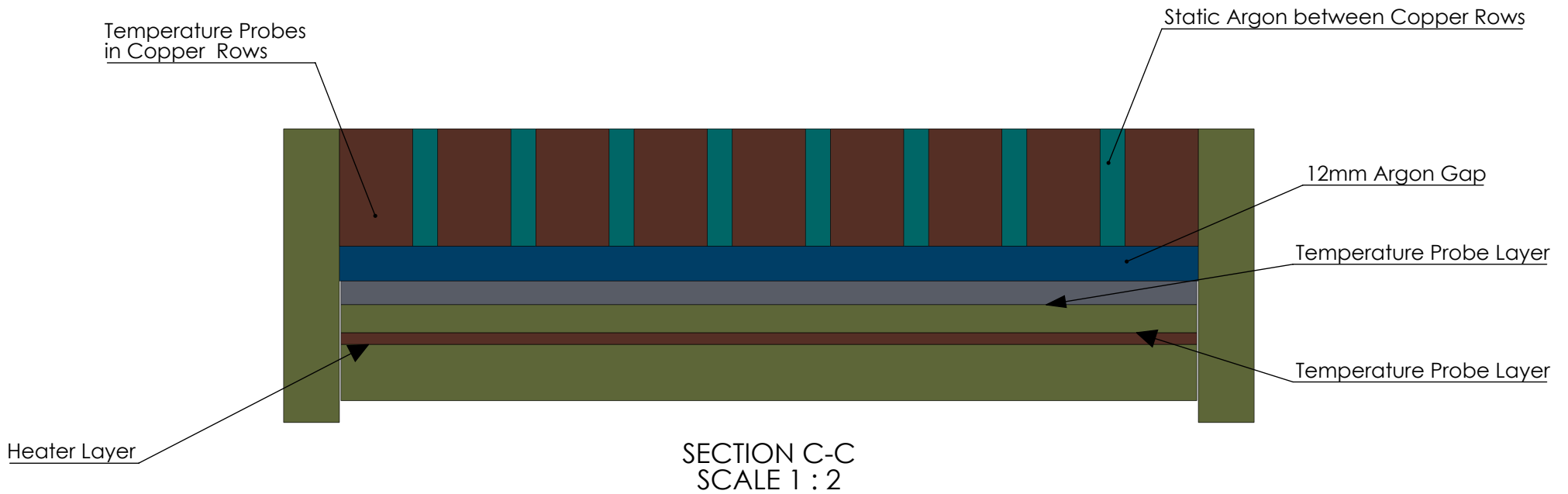
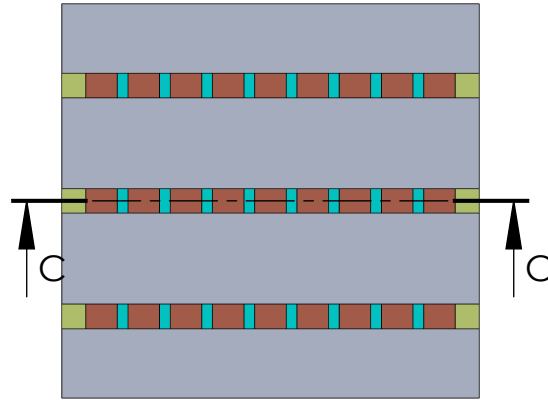

03/18/2015

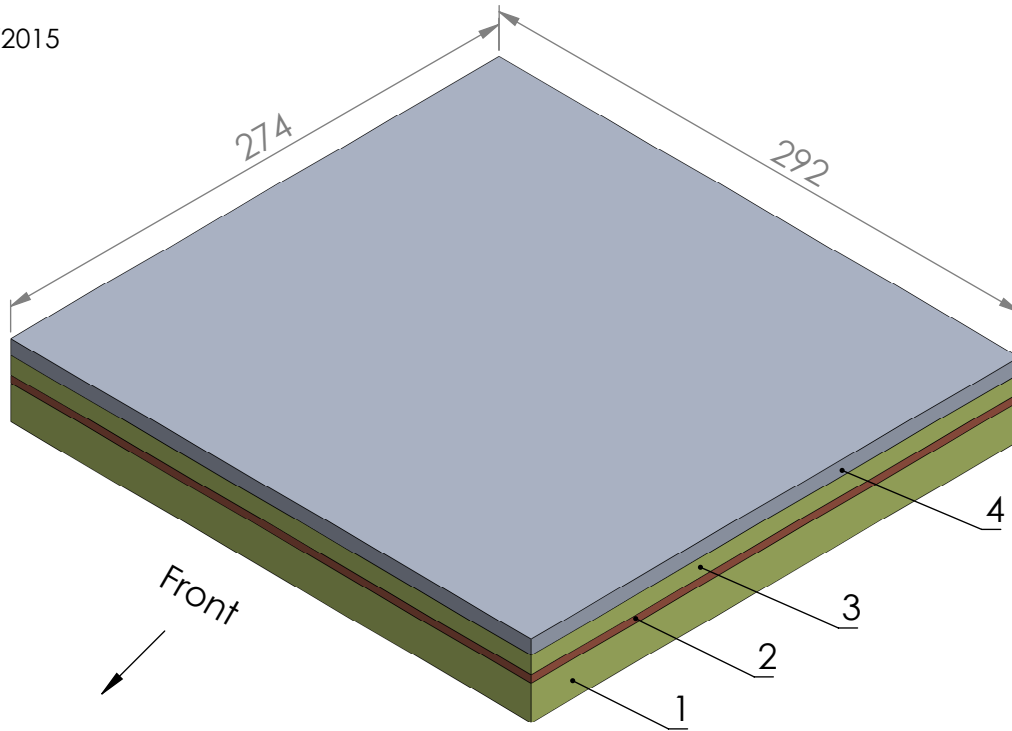

### Heater Assembly

- 1.) 19.05mm (0.75in) G-10CR Plate
- 2.) 4.064mm (5/32in) Copper Plate
- 3.) 9.525mm (3/8in) G-10CR Plate
- 4.) 8mm Aluminum Plate

