

April 29, 2015

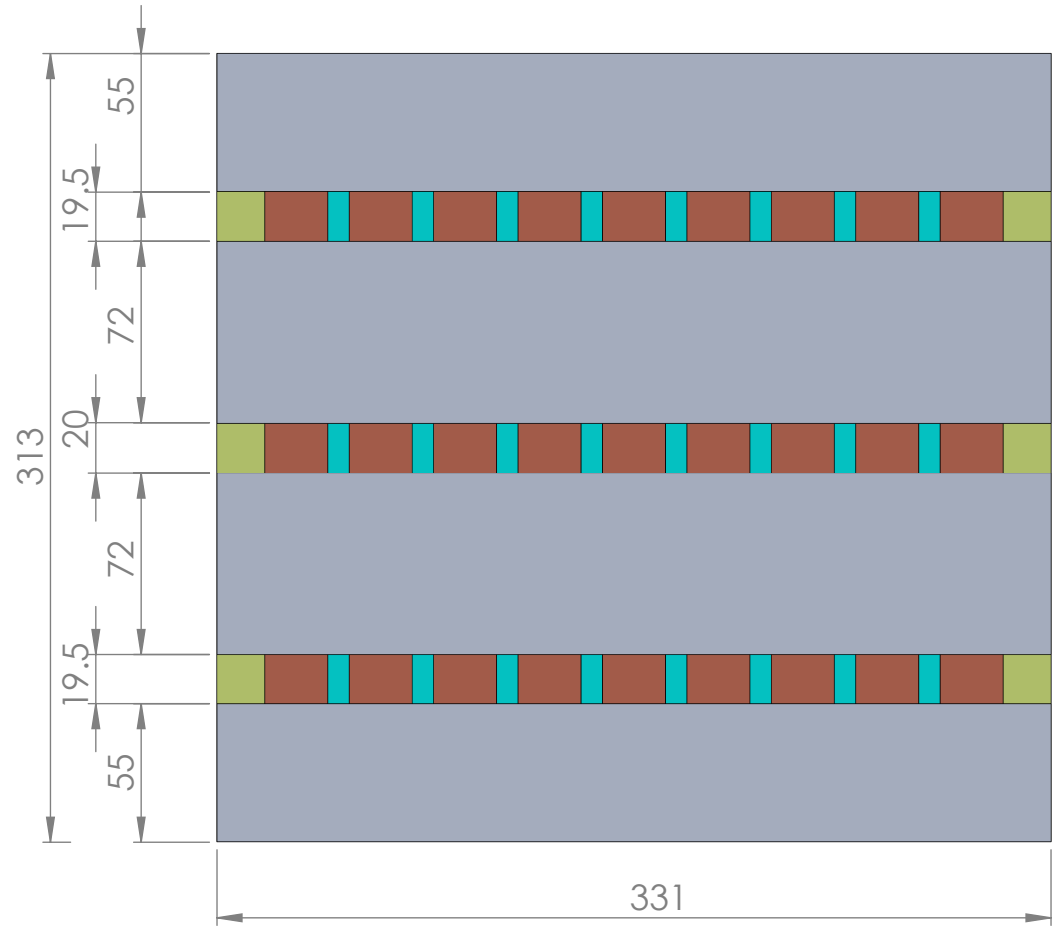

Top View

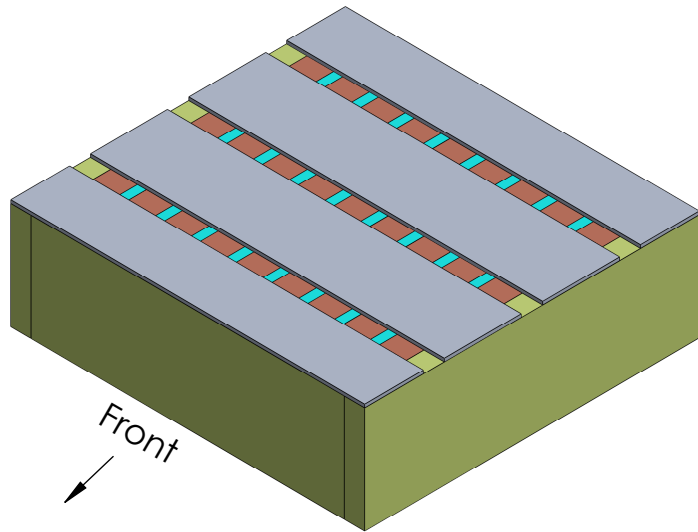

Front View

Assembly

- Top Cross Bars: Aluminum
- 9 Copper Rows
- All Perimeter Walls: 19.05mm (0.75in) G-10CR
- Heater Assembly on Sheet 4

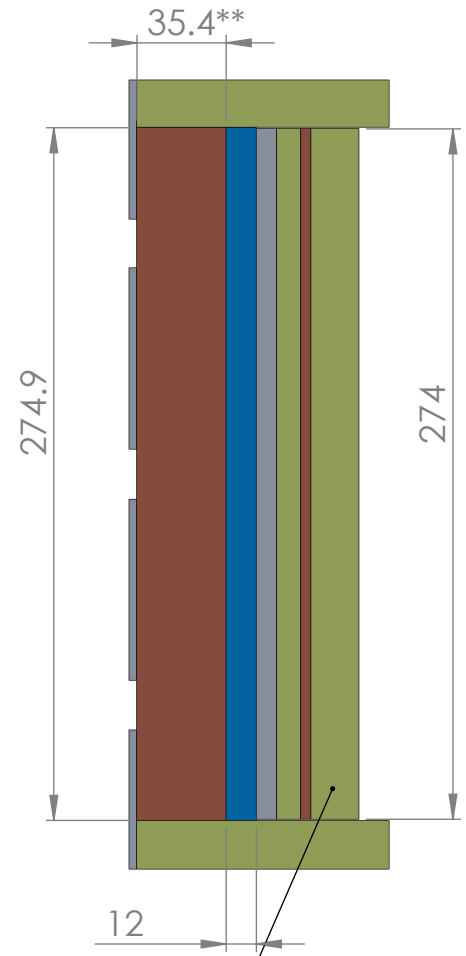
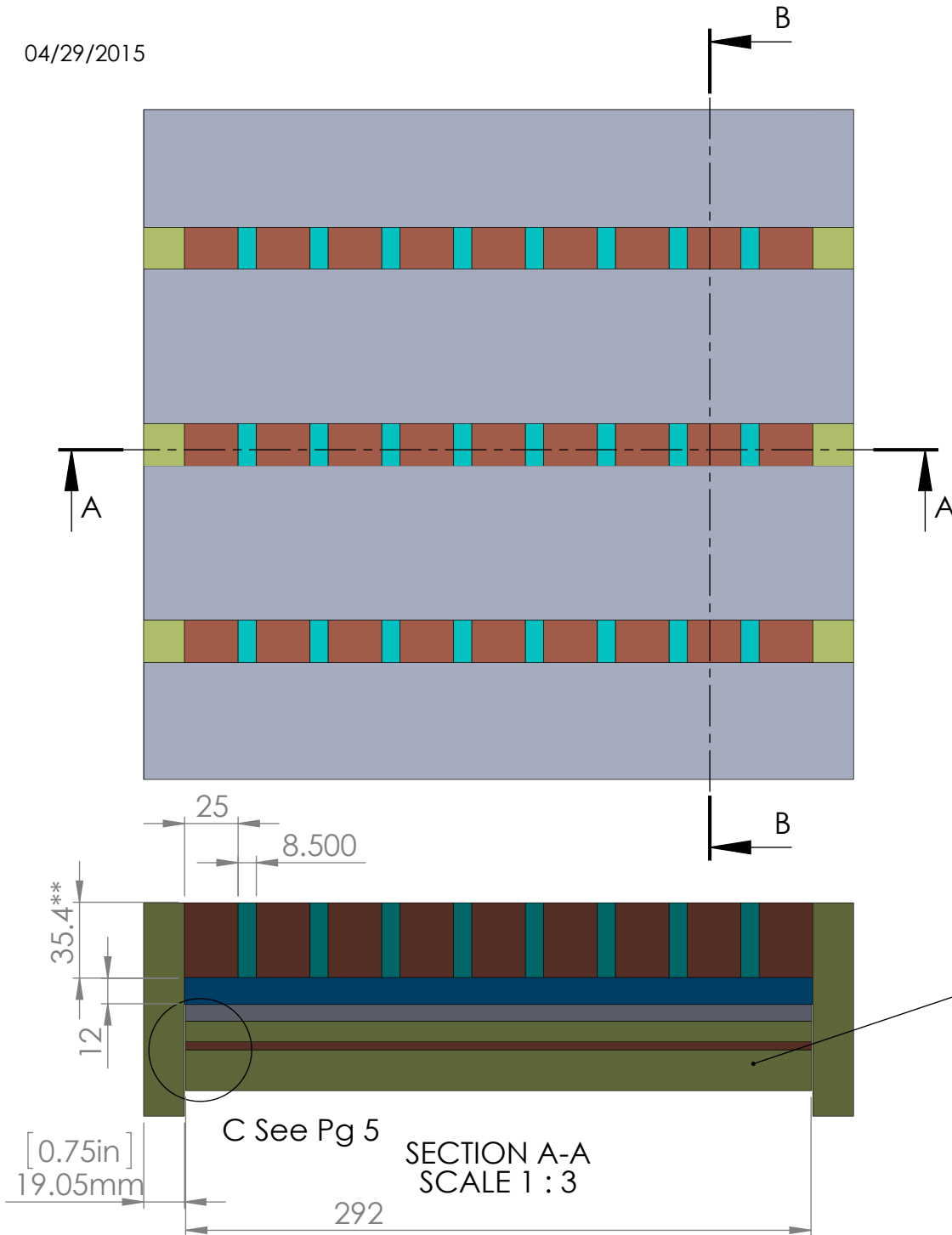

Heater Assembly Detail on Sheet 4

** Note: The 35.4mm tall copper blocks have been reduced from a size of 40mm to account for the difference in mass between the simulation volume and the "as built" volume. The rest of the model remains unchanged.

04/29/2015

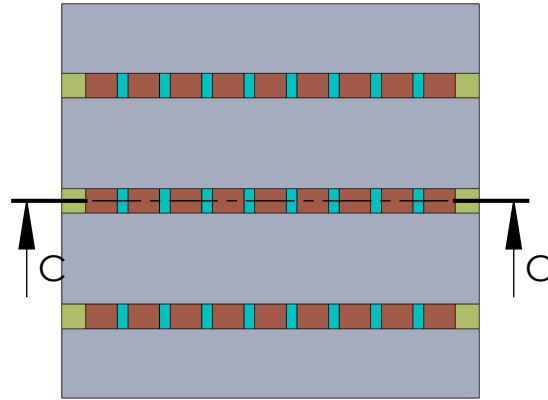

Temperature Probes
in Copper Rows

Static Argon between Copper Rows

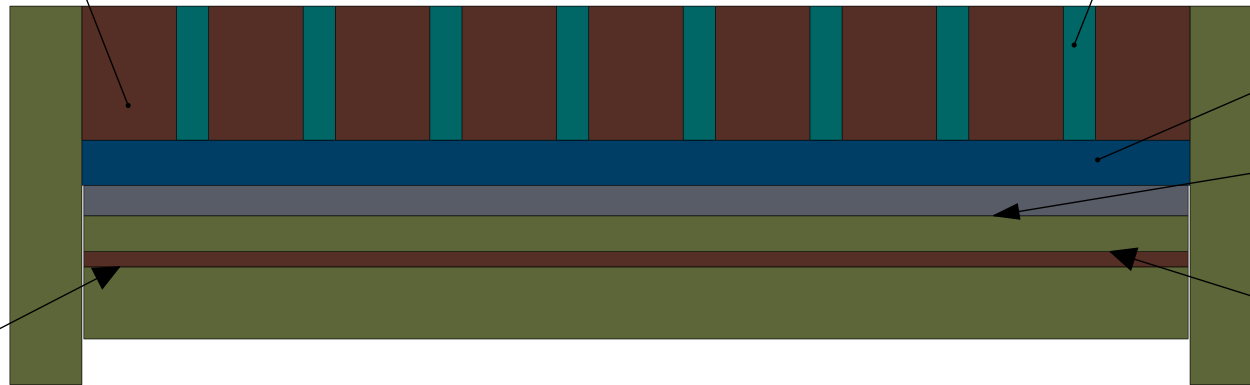

12mm Argon Gap

Temperature Probe Layer

Temperature Probe Layer

Heater Layer

SECTION C-C
SCALE 1 : 2

04/29/2015

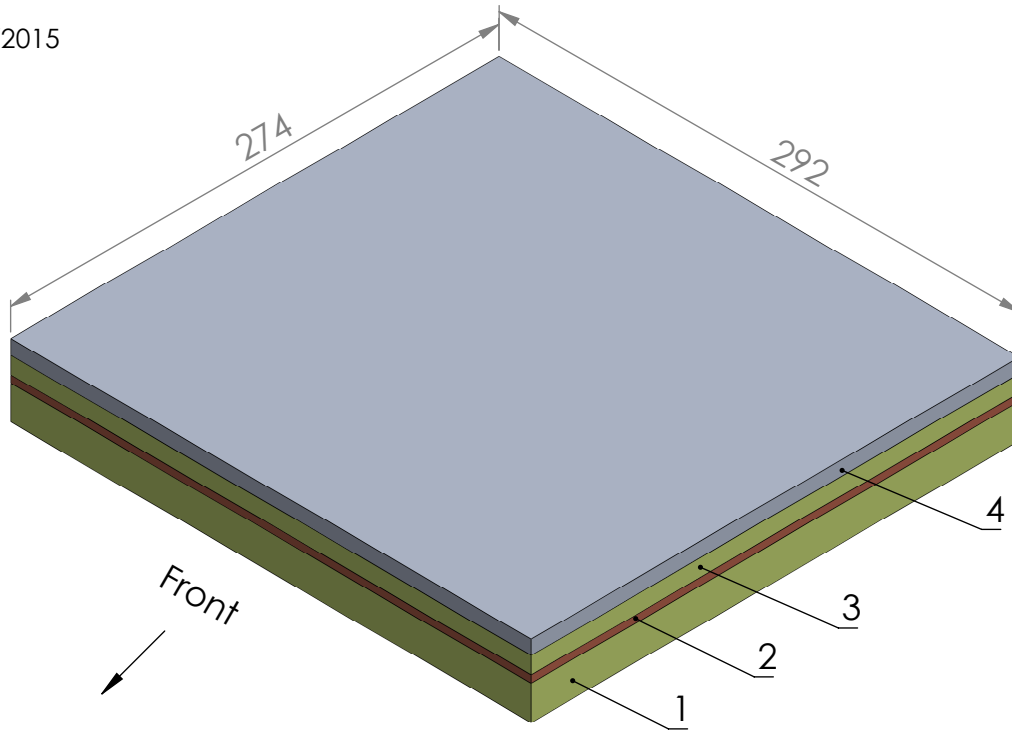

Heater Assembly

- 1.) 19.05mm (0.75in) G-10CR Plate
- 2.) 4.064mm (5/32in) Copper Plate
- 3.) 9.525mm (3/8in) G-10CR Plate
- 4.) 8mm Aluminum Plate

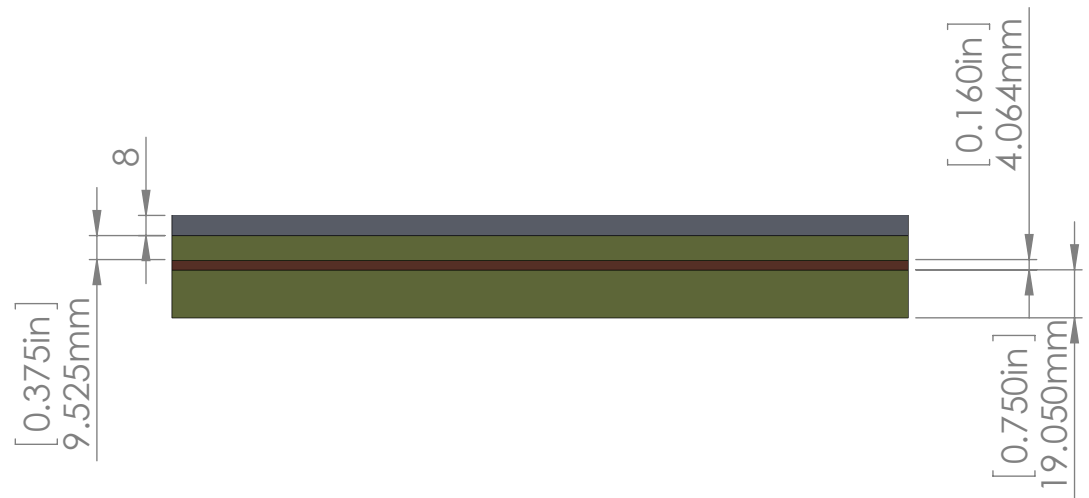

4/29/2015

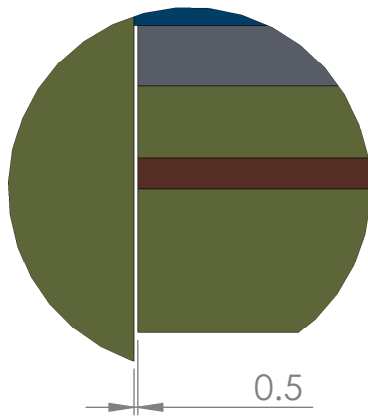

DETAIL C
SCALE 1 : 1

Note: Detail C shows the gap between the heater block and the walls of the mockup. Ideally a 0.5mm gap is present between all the G-10CR walls and the heater block. However, due to the way the walls and heater block are secured, the 293mm long walls are free to be pulled into contact with the heater block, reducing the gap size to near zero along these two walls.