

REVISIONS			
REV.	DESCRIPTION	DATE	APPROVED
A	INITIAL RELEASE	07/21/2014	RW

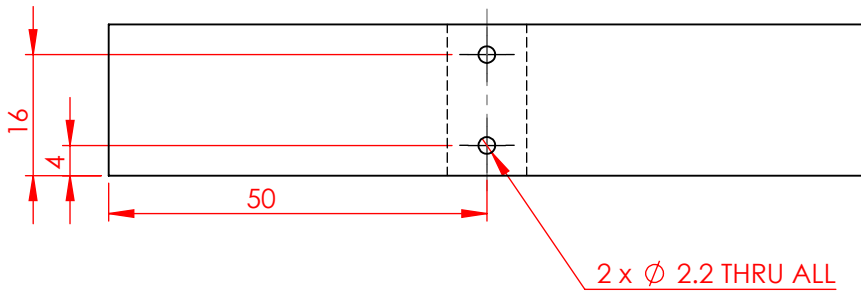
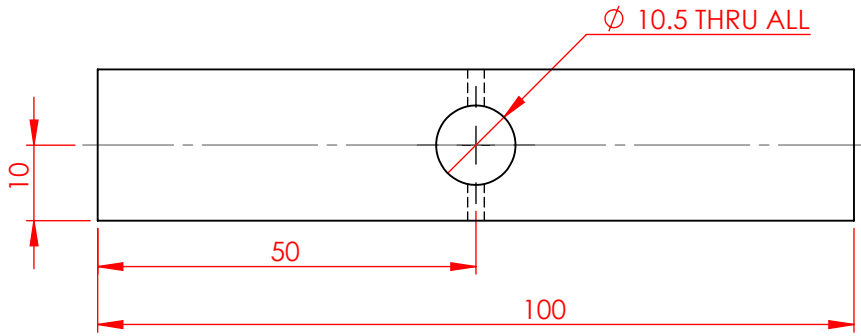

NOTES:

1. ALL DIMENSIONS IN MM
2. QTY: 1

UNLESS OTHERWISE SPECIFIED: DIMENSIONS ARE IN MILLIMETERS SURFACE FINISH: TOLERANCES: LINEAR: ANGULAR:		FINISH:	DEBUR AND BREAK SHARP EDGES	DO NOT SCALE DRAWING	REVISION A
NAME	SIGNATURE	DATE		TITLE: PushRodHandle	
DRAWN					
CHK'D					
APPV'D					
MFG					
Q.A			MATERIAL: 304 Stainless Steel	DWG NO. AZHF029	A4
			WEIGHT:	SCALE:1:2	SHEET 1 OF 1