

REVISIONS			
REV.	DESCRIPTION	DATE	APPROVED
A	INITIAL RELEASE	07/16/2014	RW

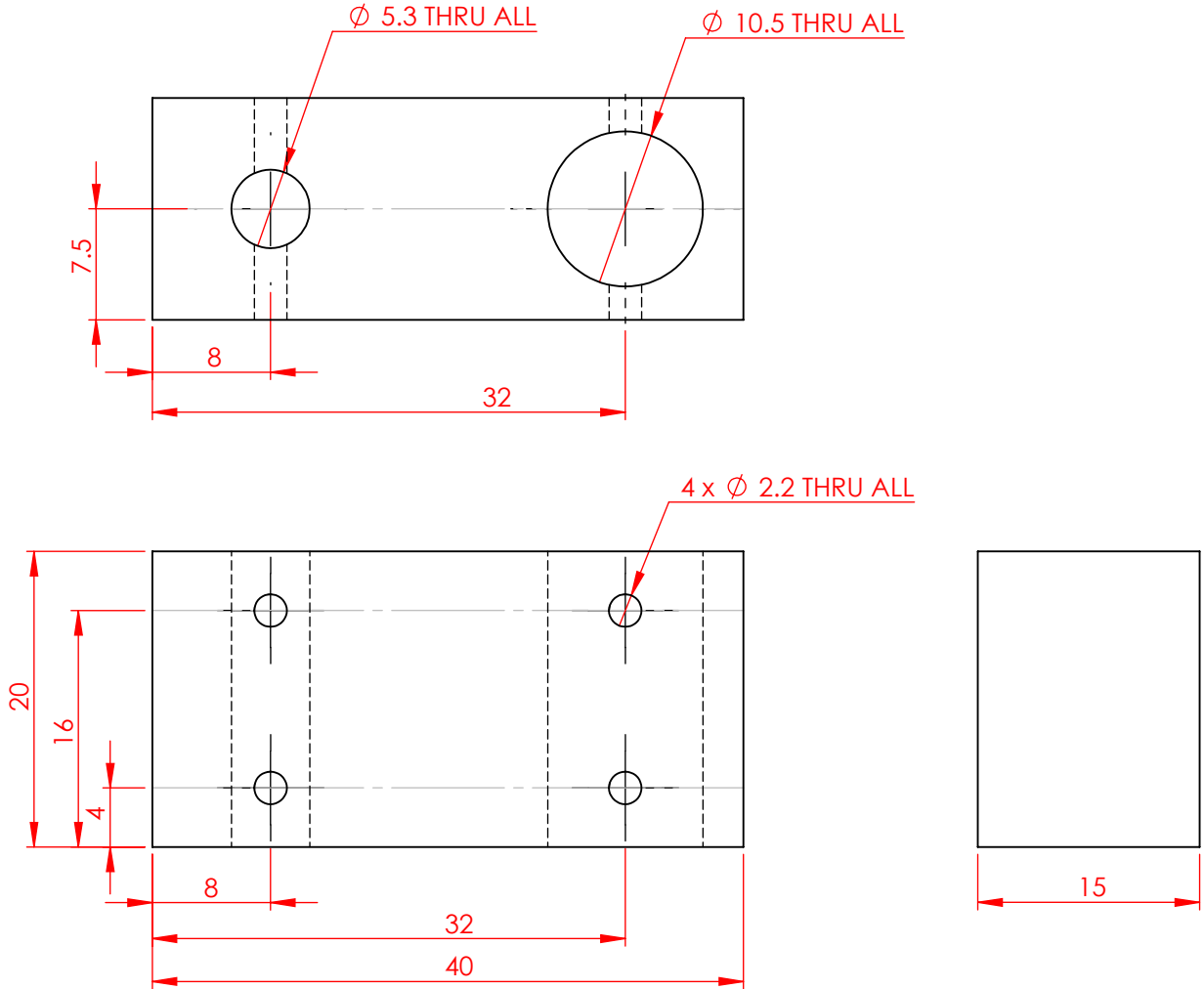

NOTES:
 1. ALL DIMENSIONS IN MM
 2. QTY: 1

UNLESS OTHERWISE SPECIFIED: DIMENSIONS ARE IN MILLIMETERS SURFACE FINISH: TOLERANCES: LINEAR: ANGULAR:		FINISH:	DEBUR AND BREAK SHARP EDGES	DO NOT SCALE DRAWING	REVISION A
NAME	SIGNATURE	DATE		TITLE: PullRodOffset	
DRAWN					
CHK'D					
APPV'D					
MFG					
Q.A			MATERIAL: 304 Stainless Steel	DWG NO. AZHF028	A4
			WEIGHT:	SCALE:2:1	SHEET 1 OF 1