

REVISIONS			
REV.	DESCRIPTION	DATE	APPROVED
A	INITIAL RELEASE	07/17/2014	RW

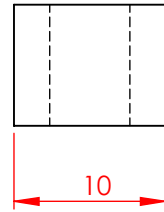
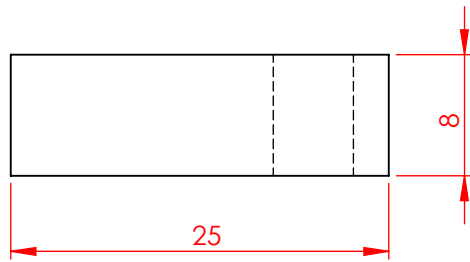
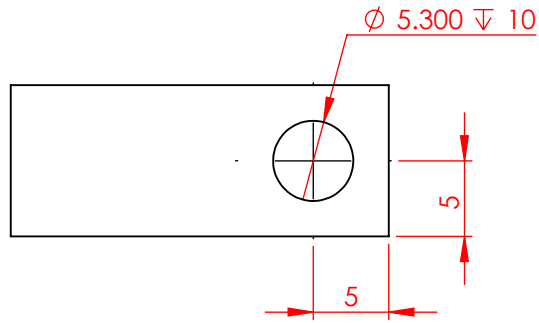

NOTES:

1. ALL DIMENSIONS IN MM
2. QTY: 1

UNLESS OTHERWISE SPECIFIED: DIMENSIONS ARE IN MILLIMETERS SURFACE FINISH: TOLERANCES: LINEAR: ANGULAR:		FINISH:		DEBUR AND BREAK SHARP EDGES		DO NOT SCALE DRAWING		REVISION A	
DRAWN		SIGNATURE		DATE		TITLE: <h1>StopperBlock</h1>			
CHK'D									
APPV'D									
MFG									
Q.A				MATERIAL: 304 Stainless Steel		DWG NO. <h1>AZHF027</h1>		A4	
				WEIGHT:		SCALE:2:1		SHEET 1 OF 1	