

REVISIONS			
REV.	DESCRIPTION	DATE	APPROVED
A	INITIAL RELEASE	4/23/2014	RW
B	DIMENSION CHANGES	5/09/2014	RW
C	SLOTS ADDED	7/15/2014	RW

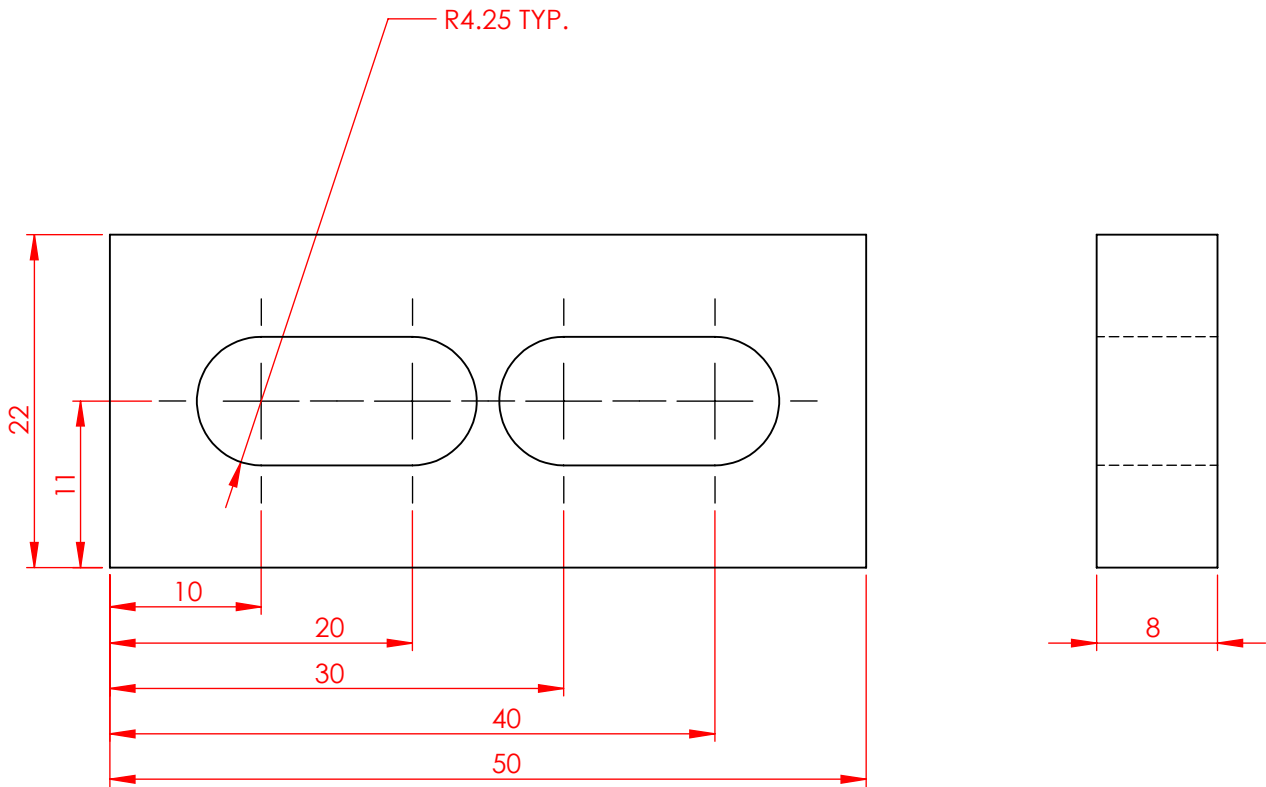

- NOTES:
1. ALL DIMENSIONS IN MM
 2. QTY: # 2
 3. PARTS TO BE WELDED TO SUSPENSION BARS (SEE AZHF017_revC)

UNLESS OTHERWISE SPECIFIED: DIMENSIONS ARE IN MILLIMETERS SURFACE FINISH: TOLERANCES: LINEAR: ANGULAR:		FINISH:	DEBUR AND BREAK SHARP EDGES	DO NOT SCALE DRAWING	REVISION C
NAME	SIGNATURE	DATE		TITLE: HangerBracket_v2	
DRAWN					
CHK'D					
APPV'D					
MFG					
Q.A			MATERIAL: 304 Stainless Steel	DWG NO. AZHF016_revC	A4
			WEIGHT:	SCALE:1:1	SHEET 1 OF 1