

REVISIONS			
REV.	DESCRIPTION	DATE	APPROVED
A	INITIAL RELEASE	4/23/2014	RW
B	DIMENSION CHANGES	5/09/2014	RW
C	DIMENSION CHANGES	7/15/2014	RW

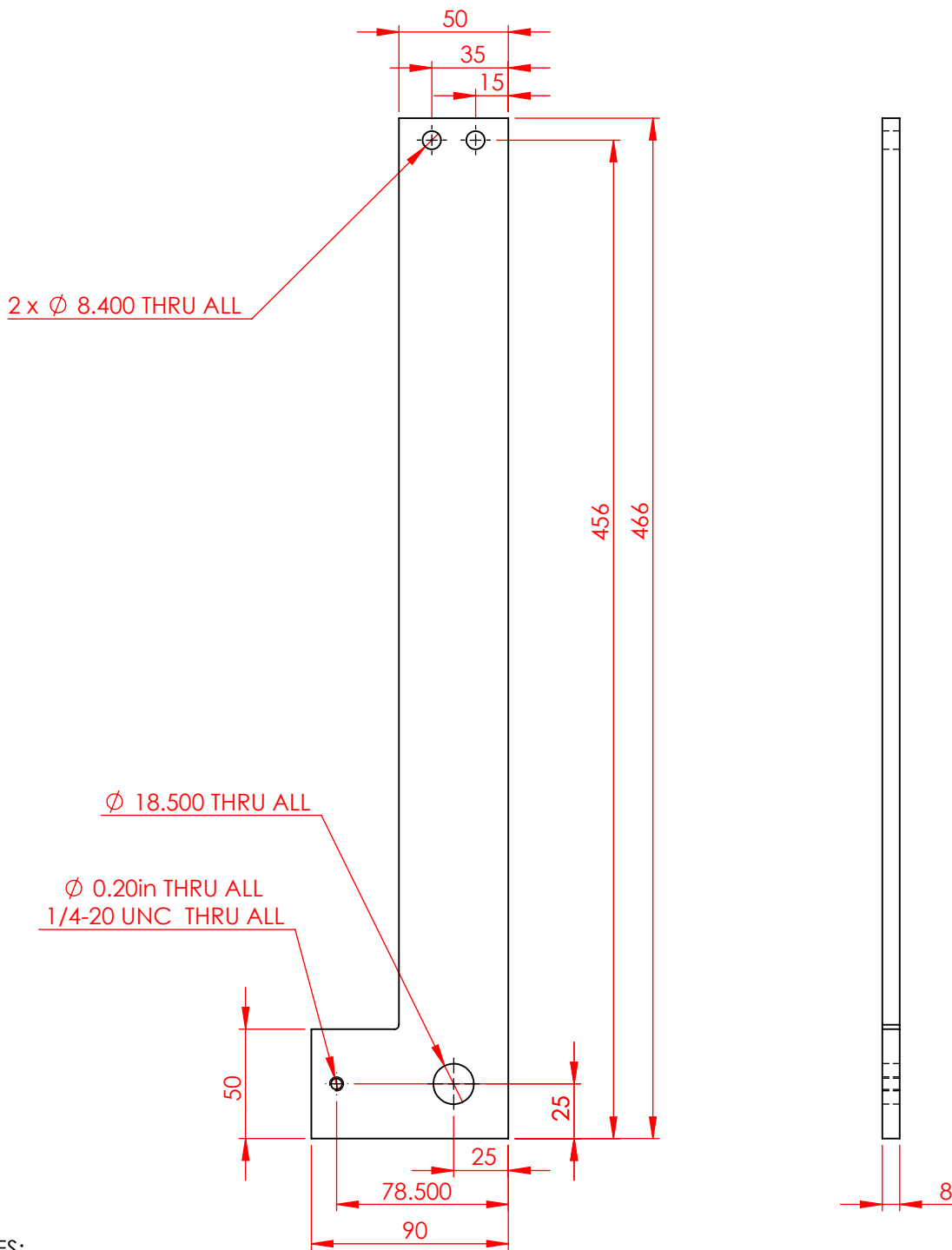

NOTES:

1. ALL DIMENSIONS IN MM UNLESS OTHERWISE STATED
2. QTY: 1

UNLESS OTHERWISE SPECIFIED: DIMENSIONS ARE IN MILLIMETERS SURFACE FINISH: TOLERANCES: LINEAR: ANGULAR:		FINISH:	DEBUR AND BREAK SHARP EDGES	DO NOT SCALE DRAWING	REVISION C
NAME	SIGNATURE	DATE		TITLE: <h1>HangerRight</h1>	
DRAWN				DWG NO.	AZHF014_revC
CHK'D					A4
APPV'D				SCALE:1:5	SHEET 1 OF 1
MFG					
Q.A			MATERIAL: 304 Stainless Steel		
			WEIGHT:		